

Seal Food Merchandiser (350 Heated)

Key Features

- Type: Heated counter-top unit
- All-round visibility
- Cabinet temperature up to 95°C
- Water and crumb tray in base
- Diffused internal light
- Adjustable shelf positions
- Supplied with two chrome-plated shelves



D3H/75

Construction

- Body: powder coated aluminium frame(silver)
- Internal components: stainless steel grade 430
- Glazing: toughened safety glass, single glazed
- Door: sliding rear doors
- Base plinth: black plastic coated steel
- Shelves: chrome plated

Available Options

- 60Hz supply (price on request)

Available Accessories

N/A

Specifications

Model	D3H/75
External height (mm)	575
External width (mm)	750
External depth (mm)	350
Capacity net volume (litre)	124
Number of Shelves (including base)	2
Shelf dimensions W x D (mm)	650 x 275
Cabinet temperature (°C)	Up to 95°C
Food holding temperature(°C)	Min 72°C
Total power rating kW	0.393
Electrical supply 1N~+E 230V 50-60Hz Current Rating (A)	4
Net weight unpacked (kg)	34
Gross weight packed (kg)	45
Shipping volume (m ³)	0.356

D3H/75

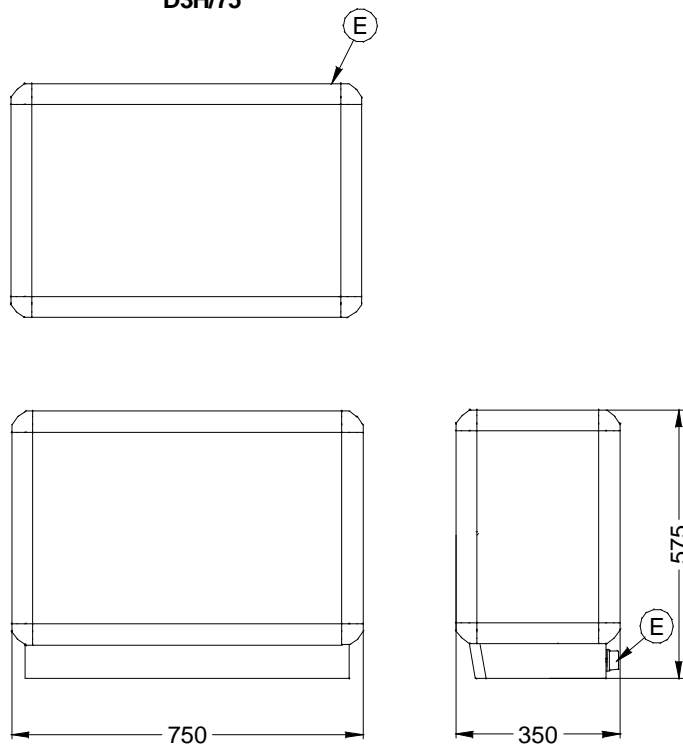

Lincat Limited, Whisby Road,
Lincoln LN6 3QZ,
United Kingdom

UK Sales Tel: 01522 875500 UK Spares Tel: 01522 875510 UK General Tel: 01522 875555
UK Fax: 01522 875530 International Sales Tel: +44 1522 503250 International Fax: +44 1522 875530
Website: www.lincat.co.uk UK Sales e-mail: sales@lincat.co.uk International Sales e-mail: export@lincat.co.uk



Document ref:
SEAL350HEAT
Issue date: Dec-09